

# ECS 203 (CPE2)

## Asst. Prof. Dr.Prapun Sukksompong

### CHAPTER 5

## Operational Amplifiers

In this chapter, we learn how to use a new circuit element called op amp to build circuits that can perform various kinds of mathematical operations. Op amp is a building block of modern electronic instrumentation. Therefore, mastery of operational amplifier fundamentals is paramount to any practical application of electronic circuits. They are popular in practical circuit designs because they are versatile, inexpensive, easy to use, and fun to work with.

### 5.1. Introduction to Op Amp

5.1.1. Operational amplifiers (or **Op Amp**) is an *active* circuit element that, by proper selection of external components, could be configured to perform mathematical operations (e.g., amplification, summation, subtraction, linear combination, integration, differentiation) between signals .

- The ability of the op amp to perform these mathematical operations is the reason it is called an operational amplifier. It is also the reason for the widespread use of op amps in analog design.

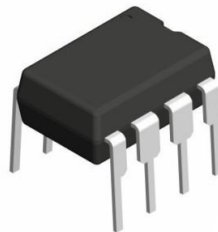

5.1.2. An op amp consisting of a complex arrangement of resistors, transistors, capacitors, and diodes. Here, we ignore the details.

5.1.3. The circuit symbol for the op amp is shown below.

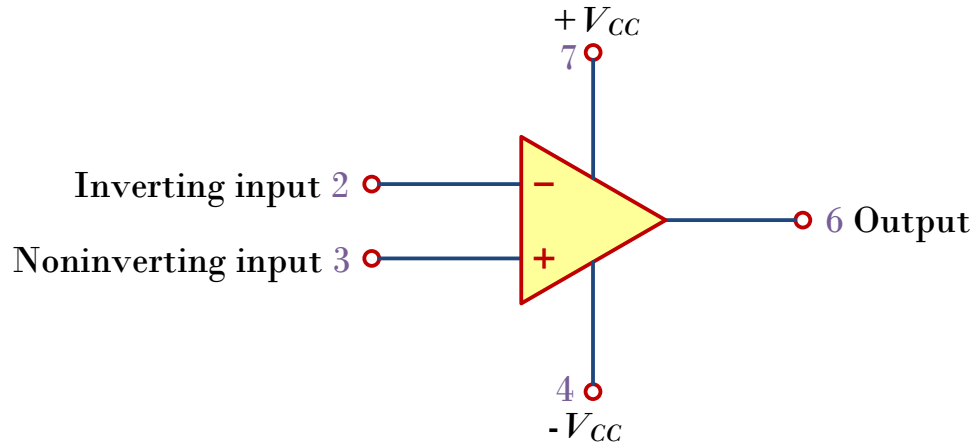

- It has two inputs and one output.
- The inputs are marked with minus (-) and plus (+) to specify inverting and noninverting<sup>1</sup> inputs, respectively.

5.1.4. As an active element, the op amp must be powered by a voltage supply:

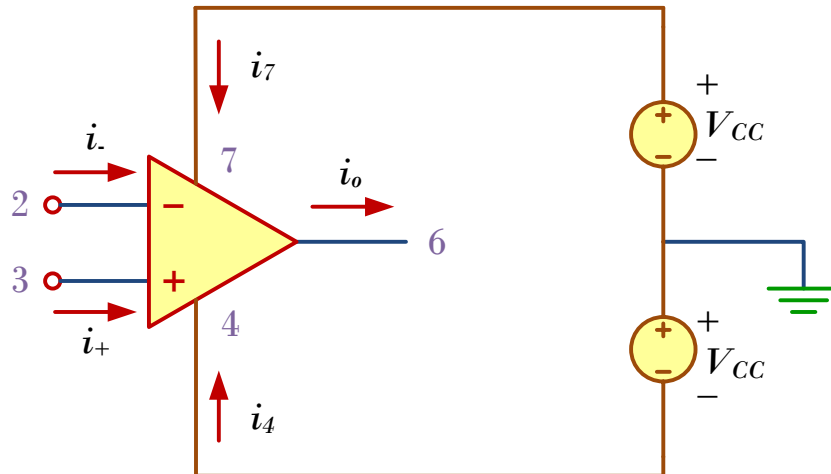

Although, in this class, the power supplies are often ignored in op amp circuit diagrams for the sake of simplicity, the power supply currents must not be overlooked:

$$i_o = i_7 + i_4 + i_+ + i_-.$$

Caution: Even when pins 7 and 4 are not shown explicitly, they are always there and the corresponding currents are also there.

<sup>1</sup>An input applied to the noninverting terminal will appear with the same polarity at the output, while an input applied to the inverting terminal will appear inverted at the output.

5.1.5. The equivalent circuit of non-ideal op amp is shown below. Note that the output section consists of a voltage-controlled source in series with the output resistance  $R_o$ .

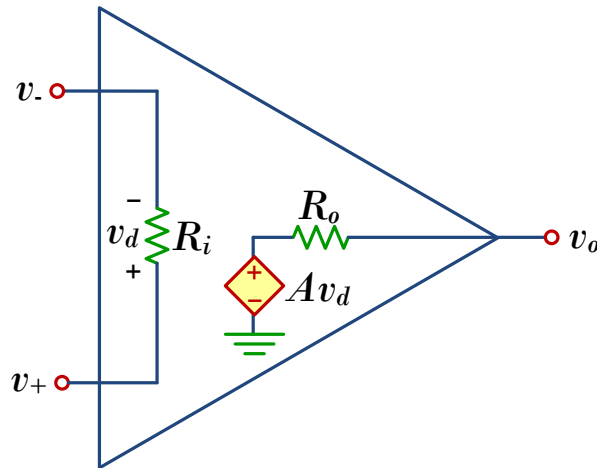

Input-output relations:

$$v_o = Av_d = A(v_+ - v_-)$$

where

- $v_o$  = voltage between the output terminal and ground
- $v_-$  = voltage between the inverting terminal and ground
- $v_+$  = voltage between the noninverting terminal and ground
- $v_d = v_+ - v_-$  = differential input voltage
- $A$  = open-loop voltage gain

- In words, the op amp senses the difference between the two inputs, multiplies it by the gain  $A$ , and causes the resulting voltage to appear at the output.

$A$  is called the open-loop voltage gain because it is the gain of the op amp *without any external feedback* from output to input.

5.1.6. The concept of feedback is crucial to our understanding of op amp circuits. A **negative feedback** is achieved when the output is fed back to the inverting terminal of the op amp.

EXAMPLE 5.1.7. Consider the circuit below. There is a feedback path from output to input. The ratio of the output voltage to the input voltage is called the **closed-loop gain**.

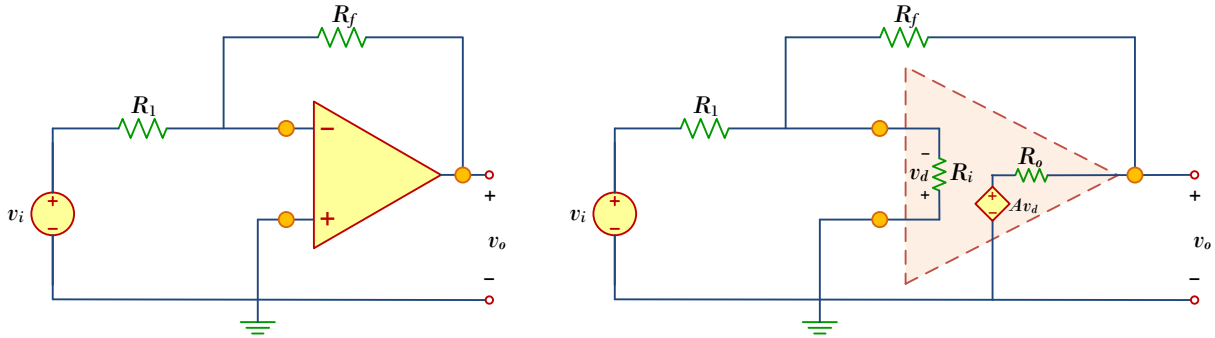

5.1.8. Typical ranges for op amp parameters are shown in the following table Working with a nonideal op amp is tedious because it involves dealing

Parameter	Typical range	Ideal values
Open-loop gain, $A$	$10^5$ to $10^8$	$\infty$
Input resistance, $R_i$	$10^5$ to $10^{13} \Omega$	$\infty \Omega$
Output resistance, $R_o$	10 to 100 $\Omega$	0 $\Omega$
Supply voltage, $V_{CC}$	5 to 24 V	

with very large numbers.

EXAMPLE 5.1.9. Consider, again, the circuit in Example 5.1.7. Suppose  $R_1 = 10 \text{ k}\Omega$  and  $R_f = 20 \text{ k}\Omega$ . Assume that the op amp has an open-loop voltage gain of  $2 \times 10^5$ , input resistance  $R_i$  of  $2 \text{ M}\Omega$ , and output resistance  $R_o$  of  $50 \Omega$ . Find the closed-loop gain  $v_o/v_i$ .

It can be shown that the closed-loop gain is almost insensitive to the open-loop gain  $A$  of the op amp. For this reason, op amps are used in circuits with feedback paths.

## 5.2. Ideal Op-Amp

To facilitate understanding, we assume ideal op amps with the ideal values above.

DEFINITION 5.2.1. An *ideal op amp* is an amplifier with infinite open-loop gain, infinite input resistance, and zero output resistance.

Unless stated otherwise,

we will assume from now on that every op amp is ideal.

### 5.2.2. Two important characteristics of the ideal op-amp:

- (a) The current into both input terminals are zero.

$$i_- = 0 \quad \text{and} \quad i_+ = 0.$$

- (b) The voltage across the input terminals is negligibly small.

$$v_d = v_+ - v_- \approx 0$$

or

$$v_+ \approx v_-.$$

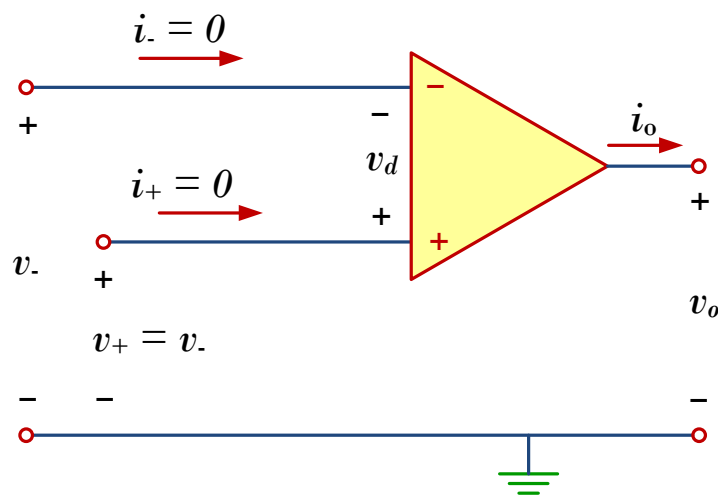

### 5.2.3. Caution:

EXAMPLE 5.2.4. An ideal op amp is used in the circuit below. Find the closed-loop gain<sup>2</sup>  $v_o/v_s$ . Determine current  $i_o$  when  $v_s = 1$  V.

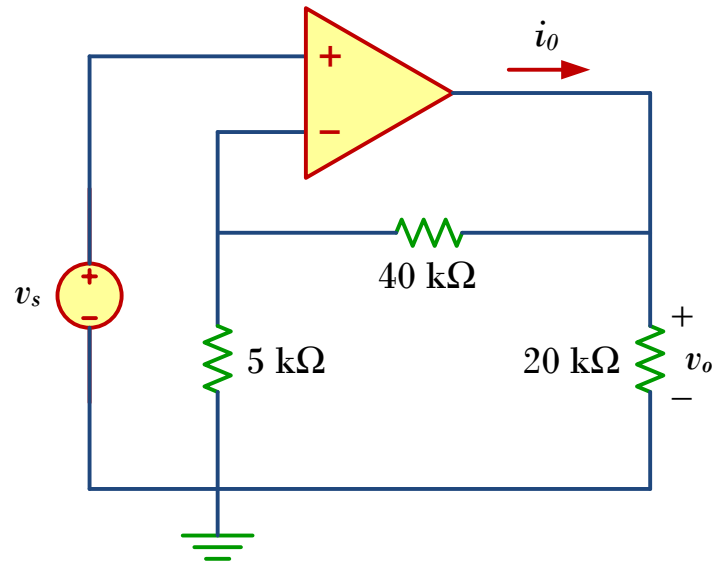

---

<sup>2</sup>closed-loop gain = ratio of the output voltage to the input voltage.

### 5.3. Inverting Amplifier

Op amp can be used in circuits as modules for creating more complex circuits. The first of such op-amp circuits is the inverting amplifier which **reverses the polarity of the input signal while amplifying it**. A key feature of the inverting amplifier is that both the input signal and the feedback are applied at the inverting terminal of the op amp.

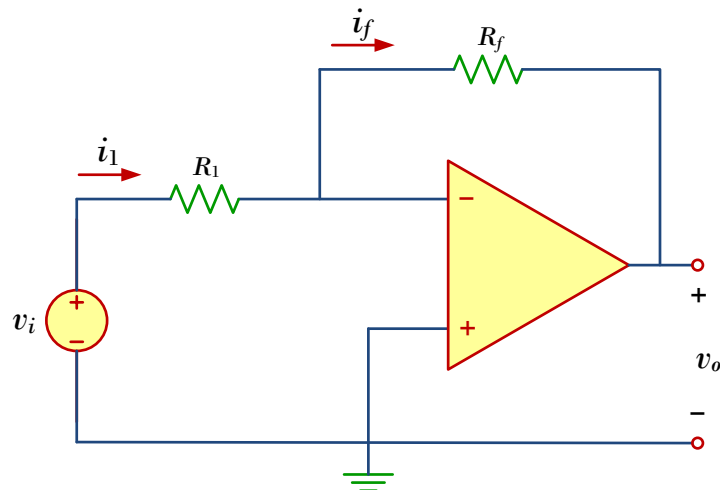

The equivalent circuit for the inverting amplifier is:

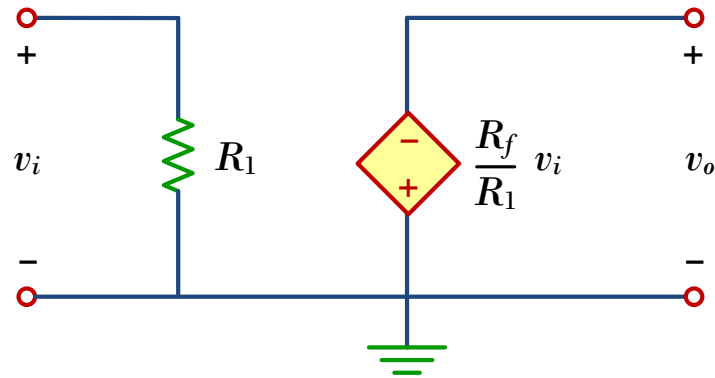

The voltage gain is  $A_v = v_o/v_i = -R_f/R_1$ .

#### 5.4. Noninverting Amplifier

A noninverting amplifier amplifies a signal by a constant positive gain (no inversion of polarity). The circuit for a noninverting amplifier is

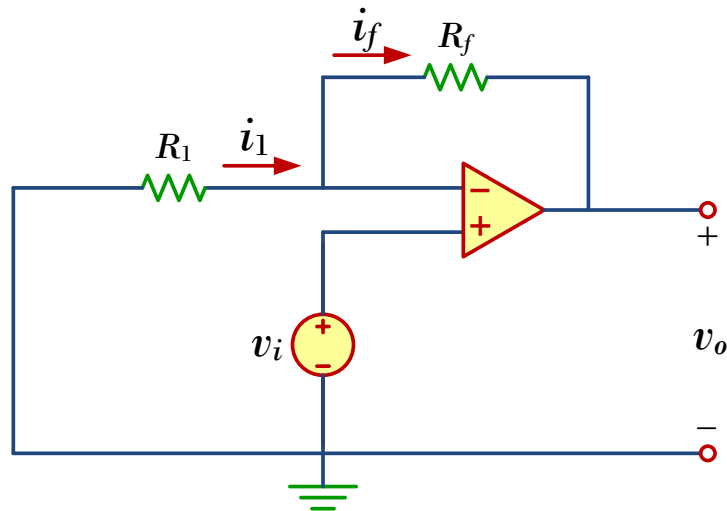



The voltage gain is  $A_v = \frac{v_o}{v_i} = 1 + \frac{R_f}{R_1}$ , which does not have a negative sign. Thus the output has the same polarity as the input.

**Special case:** If  $R_f = 0$  or  $R_1 = \infty$ , or both, the gain becomes 1. Under these conditions, the circuit becomes a **voltage follower** (The output follows the input).

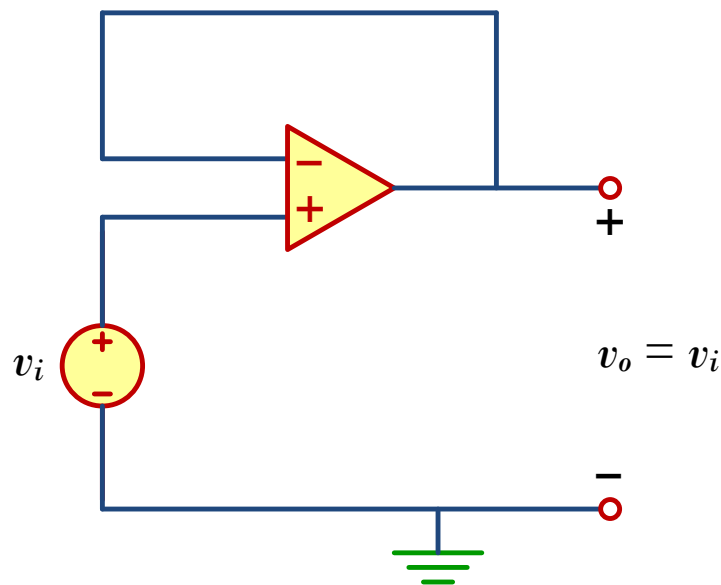

A voltage follower is used to isolate two cascaded stages of a circuit.

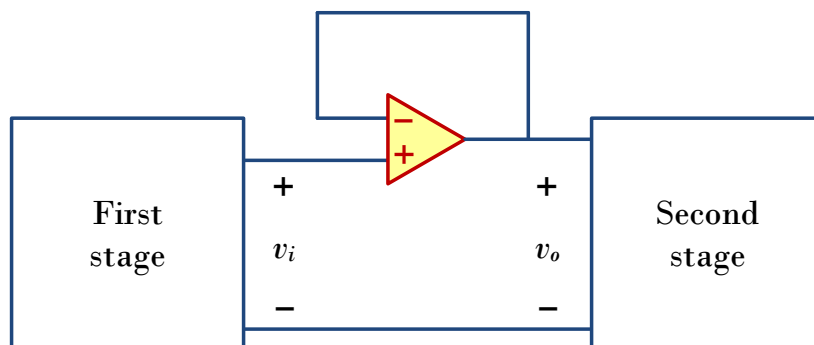

EXAMPLE 5.4.1. Calculate the output voltage  $v_o$  for the op amp circuit below.

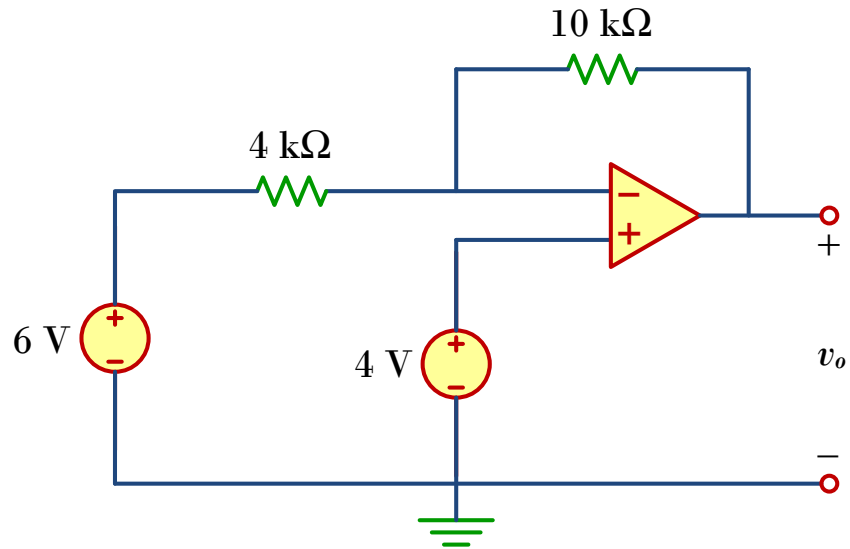

### 5.5. Summing Amplifier

A summing amplifier is an op-amp circuit that combines several inputs and produces an output that is the weighted sum of the inputs. For this reason, the circuit is called a *summer*.

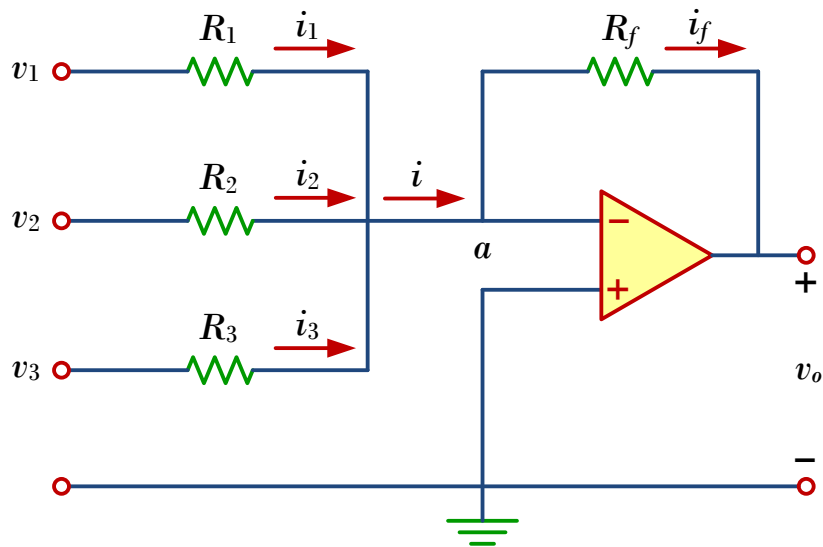

$$v_o = - \left( \frac{R_f}{R_1} v_1 + \frac{R_f}{R_2} v_2 + \frac{R_f}{R_3} v_3 \right).$$

Needless to say, the summer can have more than three inputs.

### 5.6. Difference Amplifier

A difference amplifier is a device that amplifies the difference between two inputs but rejects any signals common to the two inputs.

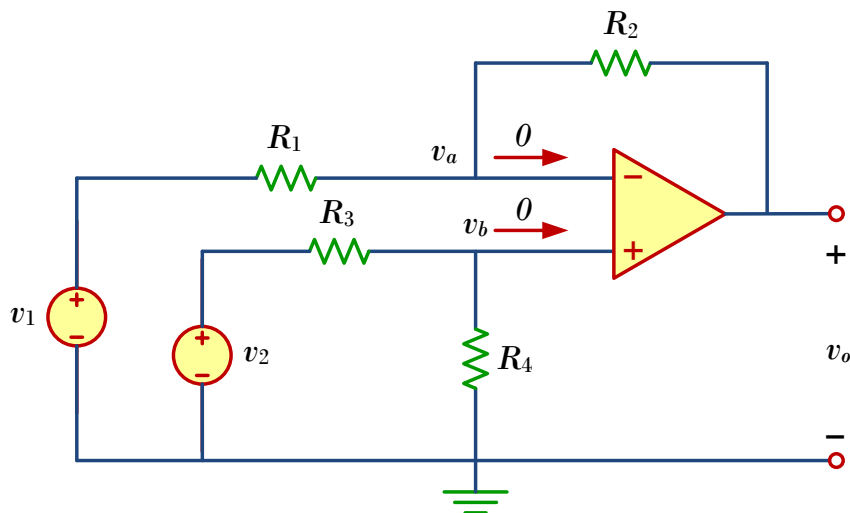

$$v_o = \frac{(1 + R_2/R_1)}{(1 + R_3/R_4)}v_2 - \frac{R_2}{R_1}v_1 = \frac{R_2(1 + R_1/R_2)}{R_1(1 + R_3/R_4)}v_2 - \frac{R_2}{R_1}v_1$$

Since a difference amplifier must reject a signal common to the two inputs, the amplifier must have the property that  $v_o = 0$  when  $v_1 = v_2$ . This property exists when

$$\frac{R_1}{R_2} = \frac{R_3}{R_4}.$$

Thus,

$$v_o = \frac{R_2}{R_1} (v_2 - v_1).$$

If  $R_2 = R_1$  and  $R_3 = R_4$ , the difference amplifier becomes a *subtractor*, with the output

$$v_o = v_2 - v_1.$$

EXAMPLE 5.6.1. Design an op amp circuit with inputs  $v_1$  and  $v_2$  such that

$$v_o = -5v_1 + 3v_2.$$

### 5.7. Cascaded of Op Amp Circuits

In practice, we can connect op amp circuits in cascade (i.e., head to tail) to achieve a large overall gain. Each circuit in the cascade is called **stage**. The output of one stage is the input to the next stage.

Op amp circuits have the advantage that they can be cascaded without changing their input-output relationships. This is due to the fact that each (ideal) op amp circuit has infinite input resistance and zero output resistance.

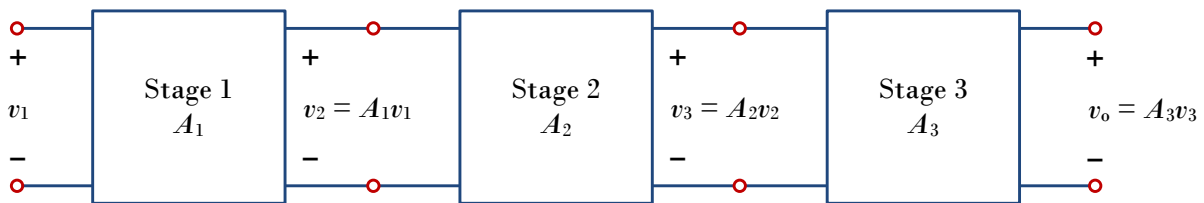

### 5.8. Application: Digital-to-Analog Converter (DAC)

The digital-to-analog converter (DAC) transforms digital signals into analog form. A typical example of a four-bit DAC is shown in (a) below.

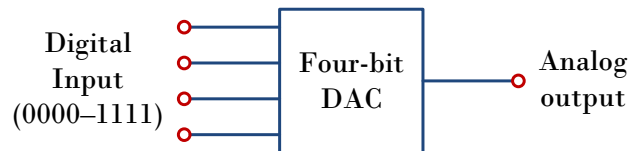

(a)

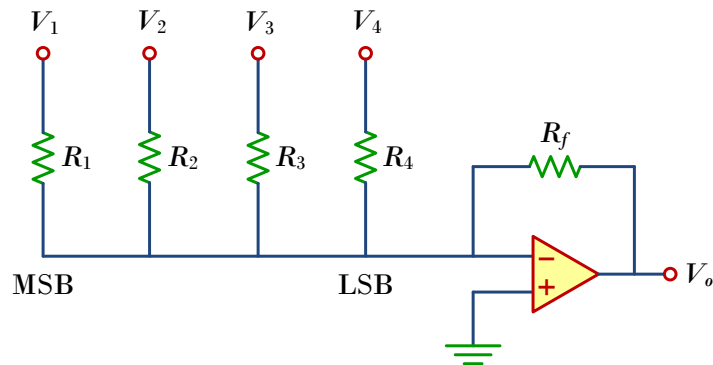

(b)